

UD info Corp.

Industrial M.2 2242 PCIe SSD BM key M2P-42DE Series Product DataSheet



© 2023 UD INFO Corp. All right reserved.

Specifications are subject to change without prior notice.

3F-4, No.8, Ln. 609, Sec. 5, Chongxin Rd., Sanchong Dist., New Taipei City 241, Taiwan (R.O.C.)

TEL: +886-2-7713-6050 FAX: +886-2-8511-3151

E-mail: sales@UDinfo.com.tw

1.	Introduction	6
1.1.	General Description	6
1.2.	Block Diagram	6
2.	Product Specifications.....	7
2.1.	Product Specifications.....	7
2.2.	Device Capacity	7
2.3.	Performance	8
2.4.	POR/SPOR Standby Ready Time	9
2.5.	Thermal Throttling.....	10
2.6.	TCG Opal 2.0.....	12
3.	Environmental Specifications	13
3.1.	Environmental Conditions	13
3.1.1.	Temperature Specification	13
3.1.2.	Mechanical Specification.....	13
3.1.3.	Electrostatic Discharge (ESD)	13
3.1.4.	EMI Compliance	14
3.2.	TBW (Terabytes Written)	14
3.3.	UBER (Uncorrectable Bit Error Rates)	15
3.4.	MTBF.....	15
4.	Electrical Specifications	16
4.1.	Supply Voltage.....	16
4.2.	Power Consumption.....	16
5.	Interface.....	17
5.1.	Pin Assignment and Descriptions	17
6.	Supported Commands.....	20
6.1.	NVMe Command List.....	20
6.2.	Identify Device Data	21
6.3.	SMART Attributes.....	26
7.	Physical Dimension	28
8.	Terminology	30

9. Barcode Description 30
10. Partnumber Decoder 31



Revision History

Revision	Draft Date	History	Author
1.0	2022/3/30	New release	Golden Lee
1.1	2022/8/26	Modify BiCS5 performance data	Golden Lee
1.2	2022/9/1	Added BiCS5 64GB/128GB support	Golden Lee
1.3	2022/9/19	<ul style="list-style-type: none"> ● Added write protect & quick erase function in pin description ● Update BiCS5 power consumption ● Removed BiCS3/BiCS4 	Golden Lee
1.4	2023/3/29	Removed safety certification	Golden Lee
1.5	2023/6/8	<ol style="list-style-type: none"> 1. Update Power consumption 2. Added 64GB support 	Golden Lee
1.6	2023/8/22	Added Extend grade: -25°C ~ 85°C series	Golden Lee

Product Overview

- **Capacity**
 - TLC: 64GB up to 2TB
- **Form Factor**
 - M.2 2242-D2-B-M
- **PCIe Interface**
 - NVMe PCIe Gen3 x2
- **Compliance**
 - NVMe 1.3
 - PCI Express Base 3.1
- **Flash Interface**
 - Transfer rate up to 800MT/s
 - Up to 4pcs BGA132 flash
- **Performance^{Note1}**
 - Read up to 1,700 MB/s
 - Write up to 1,600 MB/s
- **Power Consumption^{Note1}**
 - Active mode < 3,000 mW
 - Idle mode < 1,000 mW
- **Reliability**
 - MTBF 2,000,000 hours
 - UBER^{Note3} < 1 sector per 10¹⁶ bits read
- **Advanced Flash Management**
 - Advanced Wear Leveling
 - TRIM & SMART
- **ECC**
 - LDPC / RAID ECC
 - Low density parity check code (>120bit/Kbytes)
- **RoHS Compliant**
- **EMI Compliant**
 - EN55032, CISPR 32 (CE)
 - AS/NZS CISPR 32 (CE)
 - ANSI C63.4 (FCC)
 - CNS 13438 (BSMI)
 - VCCI-CISPR 32 (VCCI)
- **Temperature Range^{Note2}**
 - Operation Temperature:
 - Standard grade: 0°C ~ 70°C
 - Wide grade: -40°C ~ 85°C
 - Extend grade: -25°C ~ 85°C
 - Storage Temperature: -40°C ~ 85°C
- **Features Support List**
 - Thermal throttling
 - Dynamic SLC Cache
 - TCG Pyrite/OPAL^{Note4}

Notes:

1. Refer to Chapter 2 & Chapter 4 for more details.
2. The operation temperature means the case temperature, in which can be decided via S.M.A.R.T.
3. Uncorrectable Bit Error Rate (UBER)
4. Supported by a separate firmware version. Further information available upon request.

1. INTRODUCTION

1.1. General Description

UDinfo's M.2 2242 BM key PCIe solid state Drive delivers all the advantages of flash disk technology with PCIe Gen3 x2 interface and is fully compliant with the standard Next Generation Form Factor (NGFF) called M.2 Card Format. The M.2 2242 performance can reach up to 1,700MB/s read and 1,600MB/s write based on 3D NAND flash. Moreover, the power consumption of the M.2 2242 is much lower than traditional hard drives, making it the best embedded solution for new platforms.

1.2. Block Diagram

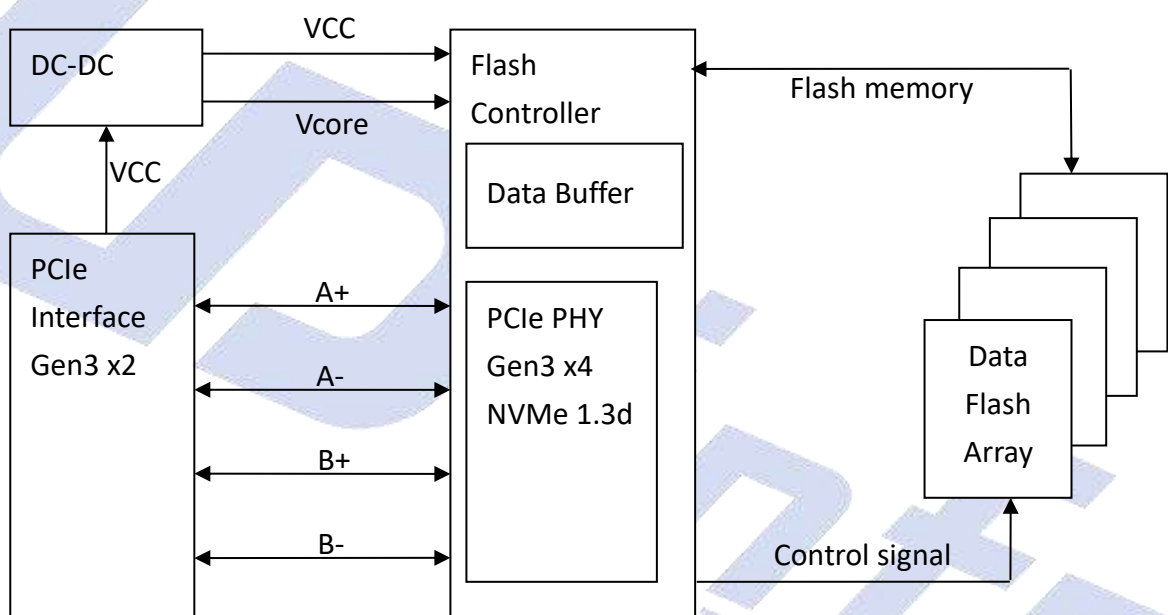

M.2 2242 PCIe SSD Block Diagram

2. PRODUCT SPECIFICATIONS

2.1. Product Specifications

- **Capacity**
 - TLC: 64GB up to 2TB
- **Electrical/Physical Interface**
 - PCI Express Base Ver 3.1 & Compliant with NVMe 1.3d
 - PCIe Gen3 x 4 lane & backward compatible to PCIe Gen2 and Gen1

2.2. Device Capacity

Capacity	IDEMA Standard		User Data Size
	512Bytes/Sector	4KBytes/Sector	
	Total Sectors (LBA)	Total Sectors (LBA)	
60GB	117,231,408	14,653,926	Depended on file management
64GB	125,045,424	15,630,678	
120GB	234,441,648	29,305,206	
128GB	250,069,680	31,258,710	
240GB	468,862,128	58,607,766	
256GB	500,118,192	62,514,774	
480GB	937,703,088	117,212,886	
512GB	1,000,215,216	125,026,902	
960GB	1,875,385,008	234,423,126	
1TB	2,000,409,264	250,051,158	
1920GB	3,750,748,848	468,843,606	
2TB	4,000,797,360	500,099,670	

Notes:

1. 1 Gigabyte (GB) is equal to 1,000,000,000 Bytes; 1 sector is equal to 512 Bytes.
2. The calculation is following IDEMA Standard.
3. The total actual user data size of the SSD may be less than device capacity due to SSD format, SSD partition, operating system.

EX: OS shows 238.47GB (NTFS) with 256GB SSD.

2.3. Performance

Capacity	Flash Structure	CrystalDiskMark		IOMeter	
		Read (MB/s)	Write (MB/s)	Read (IOPS)	Write (IOPS)
60/64GB	64GB x2, BGA, Kioxia BiCS5, SDP	1,100	550	50K	110K
120/128GB					
240/256GB	128GB x2, BGA, Kioxia BiCS5, DDP	1,700	1,100	100K	240K
480/512GB	256GB x2, BGA, Kioxia BiCS5, QDP	1,700	1,500	180K	330K
960GB/1TB	256GB x4, BGA, Kioxia BiCS5, QDP	1,700	1,600	250K	380K
1920GB/2TB	512GB x4, BGA, Kioxia BiCS5, ODP	1,700	1,600	250K	380K

Notes:

1. Performance may differ according to flash configuration and platform.
2. Performance specification is under Thermal Throttling inactivated.
3. Performance is measured with the follow conditions
 1. CrystalDiskMark 6.0, 1GB range, QD=32T1
 2. IOMeter, 1GB range, 4K data size, QD=32T8
 3. OS: Win10 64bit was, version 1809
4. Measurement environment: Room temperature: 20~25°C, humidity: 40~60%RH, DC+3.3V condition.

2.4. POR/SPOR Standby Ready Time

- POR/SPOR Ready Time

Capacity	POR ready time		SPOR ready time	
	Typ.	Max.	Typ.	Max.
128GB	120	500	2,000	10,000
256GB	120	500	2,000	10,000
512GB	120	500	2,300	18,000
1TB	120	500	2,400	18,000
2TB	120	500	3,500	30,000

Unit: ms

Notes:

1. POR/SPOR stands for following:
 - (a.) POR: Power On Ready. (The ready time variation depends on data recover size.)
 - (b.) SPOR: Power On Ready after Sudden Power Off. (The ready time variation depends on data recover size.)
2. POR/SPOR ready time stands for following:

Power on Time: From Power On to SSD response after drive ready.
3. Measurement environment: Room temperature: 20~25°C, humidity: 40~60%RH, DC+3.3V condition.

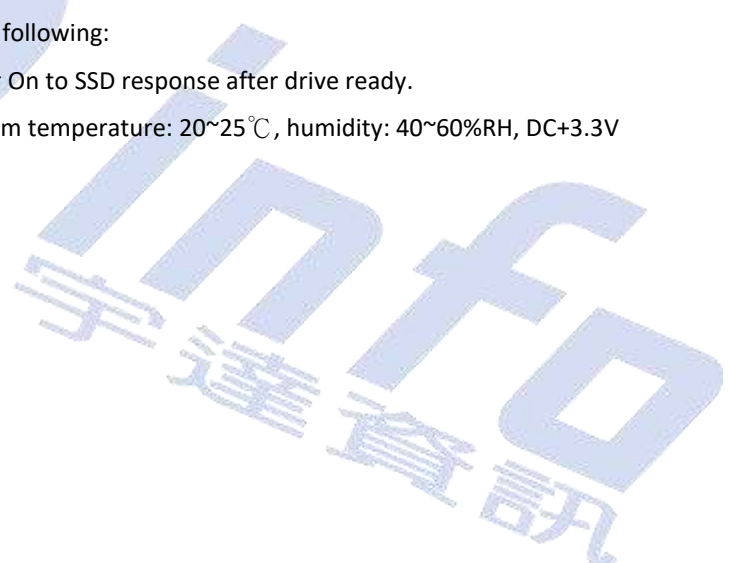

2.5. Thermal Throttling

The purpose of thermal throttling is to prevent any components in a SSD from over-heating during read and write operations. The controller is designed with an on-die thermal sensor and with its accuracy, firmware can apply different levels of throttling to achieve the purpose of protection efficiently and proactively via S.M.A.R.T. reading.

- **Purpose of Thermal Throttling:**
 - In order to keep the optimal performance in the safe range of the temperature.
- **Thermal sensors:**
 - We have external thermal sensor & on-die thermal sensor (internal controller) to detect temperature. There is 1pcs external thermal sensor on PCB, the position depends on different form factor.
 - External thermal sensor would detect flash temperature; On-die thermal sensor detect controller temperature.

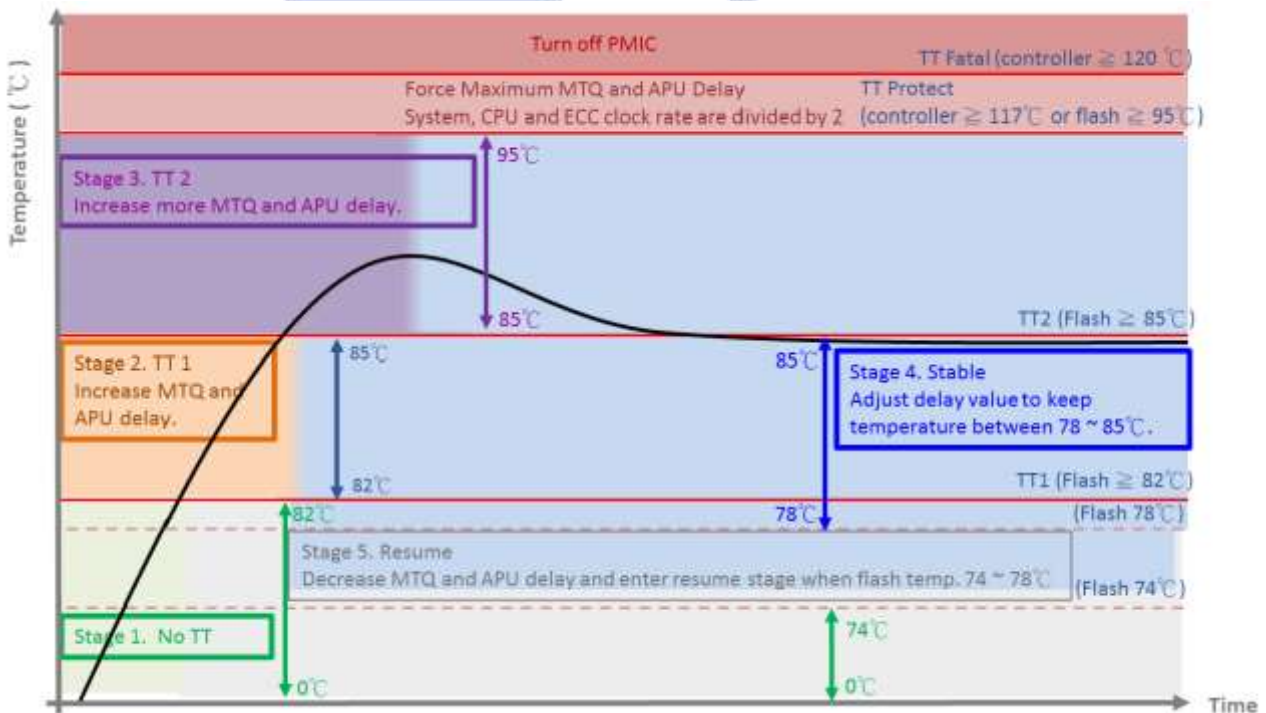

Figure 2-1 Thermal Throttling Schematic

Notes:

1. TT shown on Figure 2-1 means “Thermal Throttling”.
2. temp. = temperature

3. MTQ (Multiple Trigger Queue): Trigger multiple jobs to flash at once.
4. APU (Application Unit): APU will handle commands from HOST.



2.6. TCG Opal 2.0

The Opal specification is a set of specifications for self-encrypting drives published by the Trusted Computing Group (TCG), a non-profit organization that develops, defines, and promotes standards and specifications for secure computing. The Opal Security Subsystem Class(SSC) 2.0 defines the details of data management in storage devices and the classes authority for data access, and secures data from theft and tampering by unauthorized persons who are able to gain access to the storage device or host system.

TCG Opal 2.0 Main Features:

- AES 256-bit Hardware Self Encryption
- Deploy Storage Device & Take Ownership:
The Storage Device is integrated into its target system and ownership transferred by setting or changing the Storage Device's owner credential.
- Activate or Enroll Storage Device:
LBA ranges are configured and data encryption and access control credentials (re)generated and/or set on the Storage Device. Access control is configured for LBA range unlocking.
- Lock & Unlock Storage Device:
Unlocking of one or more LBA ranges by the host and locking of those ranges under host control via either an explicit lock or implicit lock triggered by a reset event. MBR shadowing provides a mechanism to boot into a secure pre-boot authentication environment to handle device unlocking.
- Repurpose & End-of-Life:
Erasure of data within one or more.
- Physical Presence SID (PSID):
PSID is defined by TCG OPAL as a 32-character string and the purpose is to revert SSD back to its manufacturing setting when the drive is still OPAL-activated. PSID code can be printed on a SSD label when an OPAL-activated SSD supports PSID revert feature.

3. ENVIRONMENTAL SPECIFICATIONS



3.1. Environmental Conditions

3.1.1. Temperature Specification

	Mode	Min.	Max.	Unit
Temperature Ranges	Operation (Standard)	0	70	°C
	Operation (Wide)	-40	85	°C
	Storage	-40	85	°C
Humidity	Operation	-	95	%
	Storage	-	95	%
Temperature Cycle Test	Operation (Standard)	0	70	°C
	Operation (Wide)	-40	85	°C
	Storage	-40	85	°C

Notes:

- The operation temperature means the case temperature, in which can be detected via the S.M.A.R.T. Airflow is suggested and it will allow device to be operated at appropriate temperature for each component during heavy workloads environment.

3.1.2. Mechanical Specification

Items			Condition
Shock	Non-operational	Acceleration Force	1500G 0-p with half sine wave (0.5ms)
Vibration	Non-operational	Frequency/Displacement	20Hz~80Hz/1.52mm
		Frequency/Acceleration	80Hz~2000Hz/20G p-p with sine wave
Drop	Non-operational	Height of Drop	80cm free fall
		Number of Drop	6 face of each unit
		Conflicting Material	Concrete floor

3.1.3. Electrostatic Discharge (ESD)

Specification	+/- 4KV
EN 55024, CISPR 24 EN 61000-4-2 and IEC 61000-4-2	Device functions are affected, but EUT will be back to its normal or operational state automatically.

3.1.4. EMI Compliance

EMI Compliance
EN 55032, CISPR 32 (CE)
AS/NZS CISPR 32 (CE)
ANSI C63.4 (FCC)
VCCI-CISPR 32 (VCCI)
CNS 13438 (BSMI)

3.2. TBW (Terabytes Written)

Capacity	Flash Type	TBW
60/64GB	64GB x 2, BGA, Kioxia BiCS5	110
120/128GB		110
240/256GB	128GB x 2, BGA, Kioxia BiCS5	240
480/512GB	256GB x 2, BGA, Kioxia BiCS5	520
960GB/1TB	256GB x 4, BGA, Kioxia BiCS5	1120
1920GB/2TB	512GB x 4, BGA, Kioxia BiCS5	2400

Notes:

- TBW is measured by JEDEC Client 219A workload.
 - TLC: Calculated with PE count = 3000.
- TBW may differ according to flash configuration and platform.
- The SSD supports trim function. If Operation System does not support trim command, performance and TBW will be affected. (Like certain Windows OS, Linux kernel version before 2.6.33, other OS please reference each own user manual)
- The endurance of SSD could be estimated based on user behavior, NAND endurance cycles, and write amplification factor.

3.3. UBER (Uncorrectable Bit Error Rates)

Capacity	UBER
TLC: 64GB ~ 2TB	< 1 sector per 10 ¹⁶ bits read

Notes:

1. UBER (Uncorrectable Bit Error Rates) means the uncorrectable error per bits read.
2. UBER = FER (fail rate) / Data Size (user data bit).
3. FER = uncorrectable ECC frame number / total ECC frame number.
4. The LDPC for TLC ECC capability > 120bit/KB.

3.4. MTBF

MTBF, Mean Time between Failures, is a measure of reliability of a device. Its value represents the average time between a repair and the next failure. The unit of MTBF is in hours. The higher the MTBF value, the higher the reliability of the device.

Our MTBF result is based on simulation software (Relx 7.3). Please note that a lower MTBF should be expected for higher capacity drives, and we apply the lowest MTBF for all capacities.

Capacity	MTBF
TLC: 64GB ~ 2TB	2 million hours

4. ELECTRICAL SPECIFICATIONS



4.1. Supply Voltage

Parameter	Rating
Operating Voltage	3.3V ± 5%
Rise Time (Max/Min)	100ms / 0.1ms
Fall Time (Max/Min)	5s / 10ms
Min. off Time ^{Note1}	1s

Notes:

1. Minimum time between power removed from SSD ($V_{cc} < 100\text{ mV}$) and power re-applied to the drive.
2. Ensure the voltage of each power domain in SSD has enough time to discharge less than 0.1V.
3. Rise Time during from 10% to 90% of 3.3V.
4. Fall Time during from 90% to 10% of 3.3V.

4.2. Power Consumption

Capacity	Flash Structure	Read (Max.)	Write (Max.)
60/64GB	64GB x 2, BGA, Kioxia BiCS5	2,000	1,600
120/128GB			
240/256GB	128GB x 2, BGA, Kioxia BiCS5	2,650	2,200
480/512GB	256GB x 2, BGA, Kioxia BiCS5	2,800	2,800
960GB/1TB	256GB x 4, BGA, Kioxia BiCS5	2,900	2,850
1920GB/2TB	512GB x 4, BGA, Kioxia BiCS5	3,000	3,000

Unit: mW

Notes:

1. Use CrystalDiskMark 6.0 with the setting of 1GB. Sequentially read and write the disk for 5 times, and measure power consumption during sequential Read [1/5]~[5/5] or sequential Write [1/5]~[5/5].
2. Power Consumption may differ according to flash configuration and platform.
3. The measured power voltage is 3.3V.
4. Measurement environment: Room temperature: 20~25°C, humidity: 40~60%RH.

5. INTERFACE



5.1. Pin Assignment and Descriptions

The follow table defines the signal assignment of the internal NGFF connector for SSD usage, described in the PCI Express M.2 Specification version 1.1 of the PCI-SIG.

Pin #	SATA Pin	Description
1	GND	Ground
2	3.3V	3.3V source
3	GND	Ground
4	3.3V	3.3V source
5	N/C	No connect
6	N/C	No connect
7	N/C	No connect
8	N/C	No connect
9	N/C	No connect
10	LED1#	Open drain, active low signal. These signals are used to allow the add-in card to provide status indicators via LED devices that will be provided by the system.
11	N/C	No connect
12	Module Key B	Module Key
13	Module Key B	
14	Module Key B	
15	Module Key B	
16	Module Key B	
17	Module Key B	
18	Module Key B	
19	Module Key B	
20	N/C	No connect
21	GND	Ground
22	N/C	No connect
23	N/C	No connect
24	N/C	No connect
25	N/C	No connect
26	N/C	No connect Reserved for Write Protect function (Low Active)
27	GND	Ground

UD info CORP. TEL: +886-2-7713-6050 FAX: +886-2-8511-3151

3F-4, No.8, Ln. 609, Sec. 5, Chongxin Rd., Sanchong Dist., New Taipei City 241, Taiwan (R.O.C.)

Pin #	SATA Pin	Description
28	N/C	No connect
29	PETn1	PCIe TX Differential signal defined by the PCI Express M.2 spec
30	N/C	No connect
31	PETp1	PCIe TX Differential signal defined by the PCI Express M.2 spec
32	N/C	No connect
33	GND	Ground
34	N/C	No connect
35	PERn1	PCIe RX Differential signal defined by the PCI Express M.2 spec
36	N/C	No connect
37	PERp1	PCIe RX Differential signal defined by the PCI Express M.2 spec
38	N/C	No connect
39	GND	Ground
40	SMB_CLK (I/O)(0/1.8V)	SMBus Clock; Open Drain with pull-up on platform.
41	PETn0	PCIe TX Differential signal defined by the PCI Express M.2 spec
42	SMB_DATA (I/O)(0/1.8V)	SMBus Data; Open Drain with pull-up on platform.
43	PETp0	PCIe TX Differential signal defined by the PCI Express M.2 spec
44	N/C	No connect
45	GND	Ground
46	N/C	No connect
47	PERn0	PCIe RX Differential signal defined by the PCI Express M.2 spec
48	N/C	No connect
49	PERp0	PCIe RX Differential signal defined by the PCI Express M.2 spec
50	PERST#(I)(0/3.3V)	PE-Reset is a functional reset to the card as defined by the PCIe Mini CEM specification.
51	GND	Ground
52	CLKREQ#(I/O)(0/3.3V)	Clock Request is a reference clock request signal as defined by the PCIe Mini CEM specification; Also used by L1 PM Sub-states.
53	REFCLKn	PCIe Reference Clock signals (100 MHz) defined by the PCI Express M.2 spec.
54	N/C	No connect
55	REFCLKp	PCIe Reference Clock signals (100 MHz) defined by the PCI Express M.2 spec.
56	Reserved for MFG DATA	Manufacturing Data line. Used for SSD manufacturing only. Not used in normal operation. Pins should be left N/C in platform Socket.
57	GND	Ground

UD info CORP. TEL: +886-2-7713-6050 FAX: +886-2-8511-3151

3F-4, No.8, Ln. 609, Sec. 5, Chongxin Rd., Sanchong Dist., New Taipei City 241, Taiwan (R.O.C.)

Pin #	SATA Pin	Description
58	Reserved for MFG CLOCK	Manufacturing Clock line. Used for SSD manufacturing only. Not used in normal operation. Pins should be left N/C in platform Socket.
59	Module Key M	Module Key
60	Module Key M	
61	Module Key M	
62	Module Key M	
63	Module Key M	
64	Module Key M	
65	Module Key M	
66	Module Key M	
67	N/C	No Connect Reserved for Quick Erase function (Low Active)
68	N/C	No Connect
69	N/C	No Connect for PCIe.
70	3.3V	3.3V source
71	GND	Ground
72	3.3V	3.3V source
73	GND	Ground
74	3.3V	3.3V source
75	GND	Ground

6. SUPPORTED COMMANDS



6.1. NVMe Command List

Table 6-1 Admin Commands

Op-Code	Command Description
00h	Delete I/O Submission Queue
01h	Create I/O Submission Queue
02h	Get Log Page
04h	Delete I/O Completion Queue
05h	Create I/O Completion Queue
06h	Identify
08h	Abort
09h	Set Features
0Ah	Get Features
0Ch	Asynchronous Event Request
10h	Firmware Activate
11h	Firmware Image Download
14h	Device Self-test
15h	Namespace Attachment
18h	Keep Alive

Table 6-2 Admin Commands – NVM Command Set Specific

Op-Code	Command Description
80h	Format NVM
81h	Security Send
82h	Security Receive
84h	Sanitize

Table 6-3 NVM Commands

Op-Code	Command Description
00h	Flush
01h	Write
02h	Read
04h	Write Uncorrectable
05h	Compare
08h	Write Zeroes
09h	Dataset Management

6.2. Identify Device Data

The following table details the sector data returned by the IDENTIFY DEVICE command.

■ Identify Controller Data Structure

Bytes	O/M	Default Value	Description
01:00	M	0x1987	PCI Vendor ID (VID)
03:02	M	0x1987	PCI Subsystem Vendor ID (SSVID)
23:04	M	TBD	Serial Number (SN)
63:24	M	TBD	Model Number (MN)
71:64	M	TBD	Firmware Revision (FR)
72	M	0x01	Recommended Arbitration Burst (RAB)
75:73	M	TBD	IEEE OUI Identifier (IEEE)
76	O	0x00	Controller Multi-Path I/O and Namespace Sharing Capabilities (CMIC)
77	M	0x09	Maximum Data Transfer Size (MDTS)
79:78	M	0x0000	Controller ID (CNTLID)
83:80	M	0x00010300	Version (VER)
87:84	M	0x124F80	RTD3 Resume Latency (RTD3R)
91:88	M	0x2191C0	RTD3 Entry Latency (RTD3E)
95:92	M	0x00000100	Optional Asynchronous Events Supported (OAES)
99:96	M	0x00	Controller Attributes (CTRATT)
239:100	-	0x00	Reserved
255:240	-	0x00	Refer to the NVMe Management Interface Specification for definition
257:256	M	0x001F	Optional Admin Command Support (OACS)
258	M	0x00	Abort Command Limit (ACL)
259	M	0x03	Asynchronous Event Request Limit (AERL)
260	M	0x12	Firmware Updates (FRMW)
261	M	0x0E	Log Page Attributes (LPA)
262	M	0x0F	Error Log Page Entries (ELPE)
263	M	0x04	Number of Power States Support (NPSS)
264	M	0x01	Admin Vendor Specific Command Configuration (AVSCC)
265	O	0x01	Autonomous Power State Transition Attributes (APSTA)
267:266	M	0x0155	Warning Composite Temperature Threshold (WCTEMP)
269:268	M	0x0157	Critical Composite Temperature Threshold (CCTEMP)
271:270	O	0x2710	Maximum Time for Firmware Activation (MTFA)
275:272	O	0x00	Host Memory Buffer Preferred Size (HMPRE)
279:276	O	0x00	Host Memory Buffer Minimum Size (HMMIN)

UD info CORP. TEL: +886-2-7713-6050 FAX: +886-2-8511-3151

3F-4, No.8, Ln. 609, Sec. 5, Chongxin Rd., Sanchong Dist., New Taipei City 241, Taiwan (R.O.C.)

Bytes	O/M	Default Value	Description
295:280	O	Non-zero	Total NVM Capacity (TNVMCAP)
311:296	O	0x00	Unallocated NVM Capacity (UNVMCAP)
315:312	O	0x00	Replay Protected Memory Block Support (RPMBS)
317:316	O	0x001E	Extended Device Self-test Time (EDSTT)
318	O	0x01	Device Self-test Options (DSTO)
319	M	0x04	Firmware Update Granularity (FWUG)
321:320	M	0x0001	Keep Alive Support (KAS)
323:322	O	1	Host Controlled Thermal Management Attributes (HCTMA)
325:324	O	0x111	Minimum Thermal Management Temperature (MNTMT)
327:326	O	0x157	Maximum Thermal Management Temperature (MXTMT)
331:328	O	0x00000006	Sanitize Capabilities (SANICAP)
511:316	-	0	Reserved
NVM Command Set Attributes			
512	M	0x66	Submission Queue Entry Size (SQES)
513	M	0x44	Completion Queue Entry Size (CQES)
515:514	-	0x0000	Reserved
519:516	M	0x00000001	Number of Namespaces (NN)
521:520	M	0x005F	Optional NVM Command Support (ONCS)
523:522	M	0x0000	Fused Operation Support (FUSES)
524	M	0x01	Format NVM Attributes (FNA)
525	M	0x01	Volatile Write Cache (VWC)
527:526	M	0x00FF	Atomic Write Unit Normal (AWUN)
529:528	M	0x0000	Atomic Write Unit Power Fail (AWUPF)
530	M	0x01	NVM Vendor Specific Command Configuration (NVSCC)
531	-	0x00	Reserved
533:532	O	0x0000	Atomic Compare & Write Unit (ACWU)
535:534	-	0x0000	Reserved
539:536	O	0x00000000	SGL Support (SGLS)
703:540	-	0x00	Reserved
IO Command Set Attributes			
2047:704	-	0x00	Reserved
2079:2048	M	TBD	Power State 0 Descriptor (PSD0)
2111:2080	O	0x00	Power State 1 Descriptor (PSD1)
2143:2112	O	0x00	Power State 2 Descriptor (PSD2)
2175:2144	O	0x00	Power State 3 Descriptor (PSD3)

Bytes	O/M	Default Value	Description
2207:2176	O	0x00	Power State 4 Descriptor (PSD4)
2239:2208	O	0x00	Power State 5 Descriptor (PSD5)
2271:2240	O	0x00	Power State 6 Descriptor (PSD6)
2303:2272	O	0x00	Power State 7 Descriptor (PSD7)
2335:2304	O	0x00	Power State 8 Descriptor (PSD8)
2367:2336	O	0x00	Power State 9 Descriptor (PSD9)
2399:2368	O	0x00	Power State 10 Descriptor (PSD10)
2431:2400	O	0x00	Power State 11 Descriptor (PSD11)
2463:2432	O	0x00	Power State 12 Descriptor (PSD12)
2495:2464	O	0x00	Power State 13 Descriptor (PSD13)
2527:2496	O	0x00	Power State 14 Descriptor (PSD14)
2559:2528	O	0x00	Power State 15 Descriptor (PSD15)
2591:2560	O	0x00	Power State 16 Descriptor (PSD16)
2623:2592	O	0x00	Power State 17 Descriptor (PSD17)
2655:2624	O	0x00	Power State 18 Descriptor (PSD18)
2687:2656	O	0x00	Power State 19 Descriptor (PSD19)
2719:2688	O	0x00	Power State 20 Descriptor (PSD20)
2751:2720	O	0x00	Power State 21 Descriptor (PSD21)
2783:2752	O	0x00	Power State 22 Descriptor (PSD22)
2815:2784	O	0x00	Power State 23 Descriptor (PSD23)
2847:2816	O	0x00	Power State 24 Descriptor (PSD24)
2879:2848	O	0x00	Power State 25 Descriptor (PSD25)
2911:2880	O	0x00	Power State26 Descriptor (PSD26)
2943:2912	O	0x00	Power State 27 Descriptor (PSD27)
2975:2944	O	0x00	Power State 28 Descriptor (PSD28)
3007:2976	O	0x00	Power State 29 Descriptor (PSD29)
3039:3008	O	0x00	Power State 30 Descriptor (PSD30)
3071:3040	O	0x00	Power State 31 Descriptor (PSD31)
Vendor Specific			
4095:3072	O	Vendor Reserved	Vendor Specific (VS)

■ Identify Namespace Data Structure & NVM Command Set Specific

Bytes	O/M	Default Value	Description
7:0	M	TBD*	Namespace Size (NSZE)
15:8	M	TBD*	Namespace Capacity (NCAP)
23:16	M	TBD*	Namespace Utilization (NUSE)
24	M	0x00	Namespace Features (NSFEAT)
25	M	0x01	Number of LBA Formats (NLBAF)
26	M	0x00	Formatted LBA Size (FLBAS)
27	M	0x00	Metadata Capabilities (MC)
28	M	0x00	End-to-end Data Protection Capabilities (DPC)
29	M	0x00	End-to-end Data Protection Type Settings (DPS)
30	O	0x00	Namespace Multi-path I/O and Namespace Sharing Capabilities (NMIC)
31	O	0x00	Reservation Capabilities (RESCAP)
32	O	0x00	Format Progress Indicator (FPI)
33	-	0x00	Reserved
35:34	O	0x0000	Namespace Atomic Write Unit Normal (NAWUN)
37:36	O	0x0000	Namespace Atomic Write Unit Power Fail (NAWUPF)
39:38	O	0x0000	Namespace Atomic Compare & Write Unit (NACWU)
41:40	O	0x0000	Namespace Atomic Boundary Size Normal (NABSN)
43:42	O	0x0000	Namespace Atomic Boundary Offset (NABO)
45:44	O	0x0000	Namespace Atomic Boundary Size Power Fail (NABSPF)
47:46	-	0x0000	Reserved
63:48	O	0x00	NVM Capacity (NVMCAP)
103:64	-	0x00	Reserved
119:104	O	TBD **	Namespace Globally Unique Identifier (NGUID)
127:120	O	TBD **	IEEE Extended Unique Identifier (EUI64)
131:128	M	0x02090000	LBA Format 0 Support (LBAF0)
135:132	O	0x00000000	LBA Format 1 Support (LBAF1)
139:136	O	0x00000000	LBA Format 2 Support (LBAF2)
143:140	O	0x00000000	LBA Format 3 Support (LBAF3)
147:144	O	0x00000000	LBA Format 4 Support (LBAF4)
151:148	O	0x00000000	LBA Format 5 Support (LBAF5)
155:152	O	0x00000000	LBA Format 6 Support (LBAF6)
159:156	O	0x00000000	LBA Format 7 Support (LBAF7)
163:160	O	0x00000000	LBA Format 8 Support (LBAF8)
167:164	O	0x00000000	LBA Format 9 Support (LBAF9)

UD info CORP. TEL: +886-2-7713-6050 FAX: +886-2-8511-3151

3F-4, No.8, Ln. 609, Sec. 5, Chongxin Rd., Sanchong Dist., New Taipei City 241, Taiwan (R.O.C.)

Bytes	O/M	Default Value	Description
171:168	O	0x00000000	LBA Format 10 Support (LBAF10)
175:172	O	0x00000000	LBA Format 11 Support (LBAF11)
179:176	O	0x00000000	LBA Format 12 Support (LBAF12)
183:180	O	0x00000000	LBA Format 13 Support (LBAF13)
187:184	O	0x00000000	LBA Format 14 Support (LBAF14)
191:188	O	0x00000000	LBA Format 15 Support (LBAF15)
383:192	-	0x00	Reserved
4095:384	O	0x00	Vendor Specific (VS)

■ List of Identify Namespace Data Structure for Each Capacity

Capacity (GB)	Byte[7:0]: Namespace Size (NSZE)
32	3BA2EB0h
64	7740AB0h
120	DF94BB0h
128	EE7C2B0h
240	1BF244B0h
256	1DCF32B0h
480	37E436B0h
512	3B9E12B0h
960	6FC81AB0h
1024	773BD2B0h
1920	DF8FE2B0h
2048	EE7752B0h

6.3. SMART Attributes

■ SMART Attributes (Log Identifier 02h)

Bytes Index	Bytes	Description
[0]	1	Critical Warning: Error occurred if value of the bits are not zero
[2:1]	2	Composite Temperature: Flash temp value will be detected on-board thermal sensor (Unit: K)
[3]	1	Available Spare: Remaining spare capacity available. (Unit: %)
[4]	1	Available Spare Threshold: Spare capacity threshold. (Unit: %)
[5]	1	Percentage Used: Average of the Flash's block erase count / NAND EOL erase count (Unit: %)
[31:6]	26	Reserved
[47:32]	16	Data Units Read (in LBAs): Contains the number of 512byte data units the host has read from the controller. This value is reported in thousands (i.e, a value of 1 corresponds to 1000 units of 512 bytes read).
[63:48]	16	Data Units Written (in LBAs): Contains the number of 512byte data units the host has written from the controller. This value is reported in thousands (i.e, a value of 1 corresponds to 1000 units of 512 bytes written).
[79:64]	16	Host Read Commands: The number of read commands completed by the controller.
[95:80]	16	Host Write Commands: The number of read commands completed by the controller.
[111:96]	16	Controller Busy Time: The amount of time the controller is busy with I/O commands.
[127:112]	16	Power Cycles: Normal power on/off cycles count
[143:128]	16	Power On Hours (Unit: hour)
[159:144]	16	Unsafe Shutdowns: Abnormal power on/off cycles count
[175:160]	16	Media and Data Integrity Errors: The number of occurrences where the controller detected an unrecovered data integrity error.
[191:176]	16	Number of Error Information Log Entries: The number of Error Information log entries over the life of the controller.
[195:192]	4	Warning Composite Temperature Time: The amount of time that temp. over warning threshold (85°C) but less than critical threshold (95°C). (Unit: min)
[199:196]	4	Critical Composite Temperature Time: The amount of time that temp. over critical threshold (95°C). (Unit: min)
[201:200]	2	Temperature Sensor 1 (Current Temperature) (Unit: K)
[203:202]	2	Temperature Sensor 2 (N/A)

[205:204]	2	Temperature Sensor 3 (N/A)
[207:206]	2	Temperature Sensor 4 (N/A)
[209:208]	2	Temperature Sensor 5 (N/A)
[211:210]	2	Temperature Sensor 6 (N/A)
[213:212]	2	Temperature Sensor 7 (N/A)
[215:214]	2	Temperature Sensor 8 (N/A)
[511:216]	296	Reserved



7. PHYSICAL DIMENSION

- Dimension of M.2 2242 BM Key: 42mm(L) x 22mm(W) x 3.5mm

Top View

Unit : mm

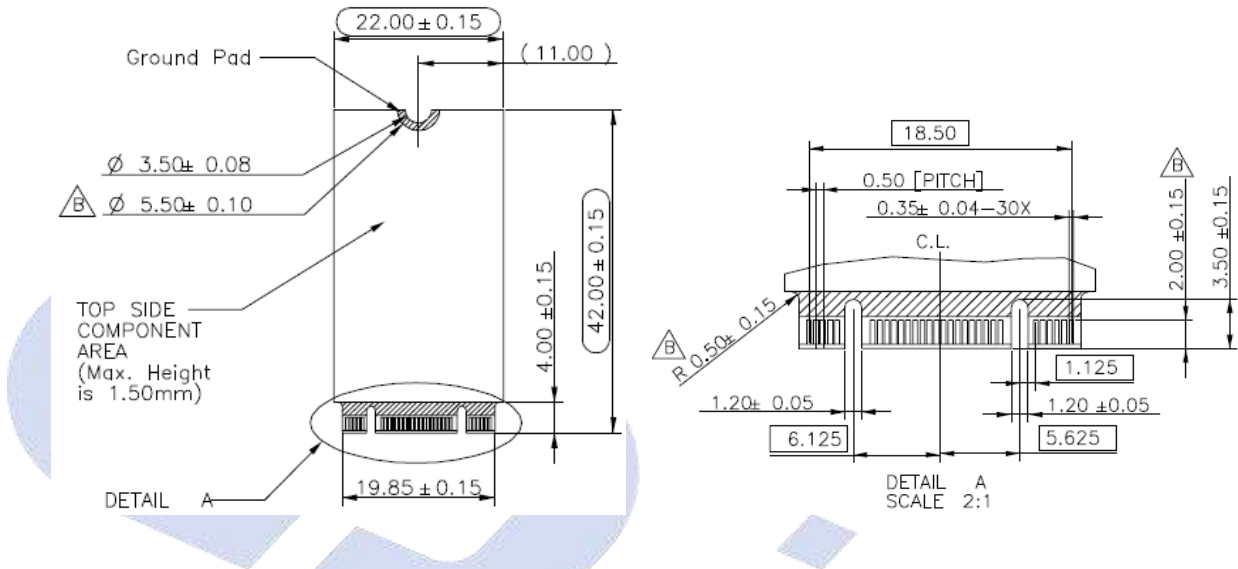

Bottom View

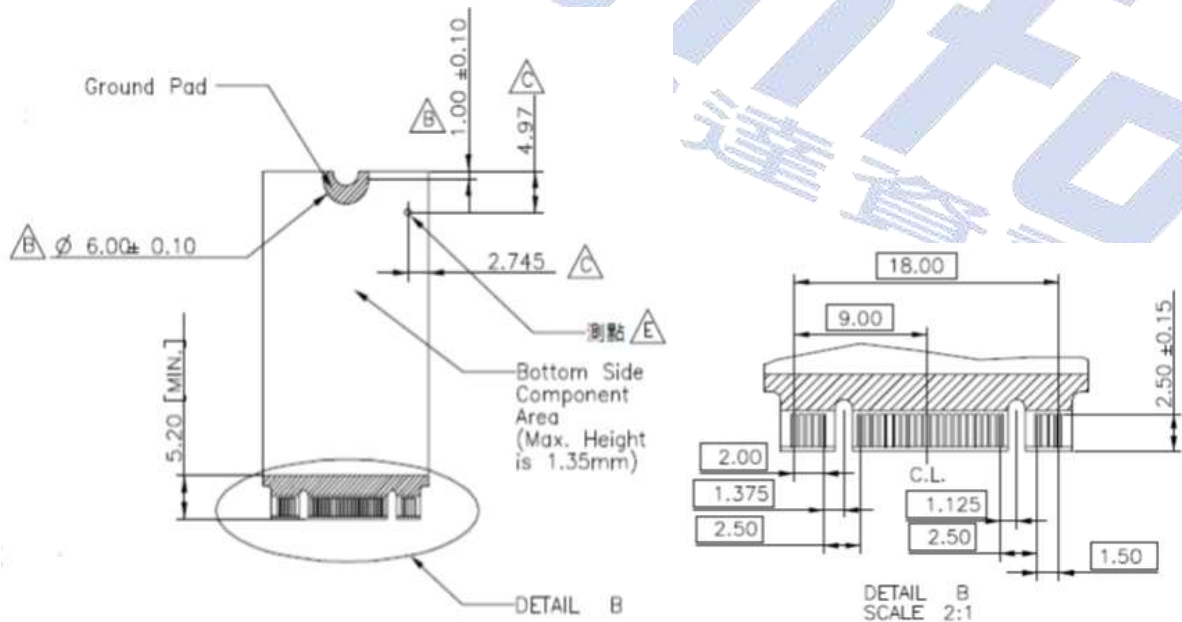

UD info CORP. TEL: +886-2-7713-6050 FAX: +886-2-8511-3151

3F-4, No.8, Ln. 609, Sec. 5, Chongxin Rd., Sanchong Dist., New Taipei City 241, Taiwan (R.O.C.)

Side View

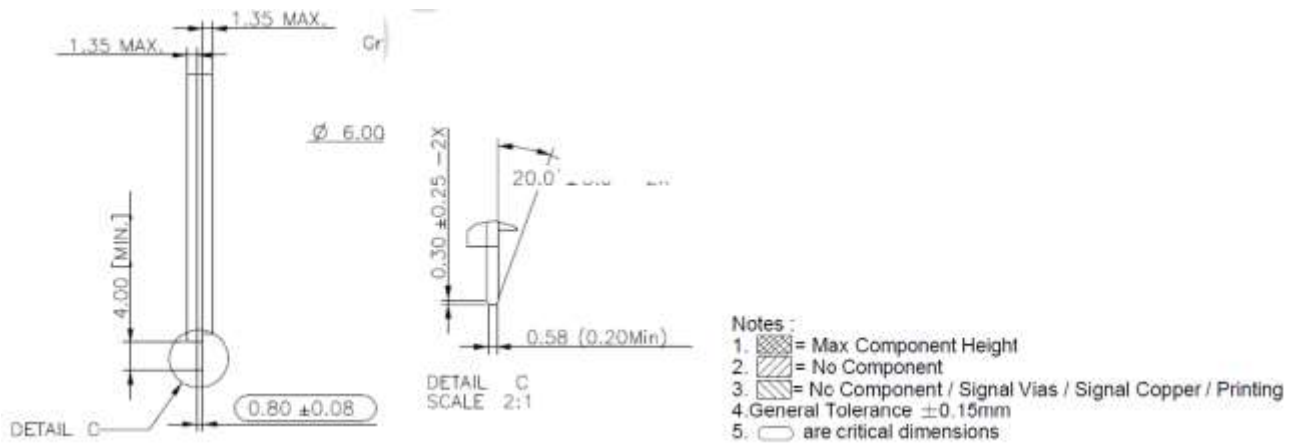

8. TERMINOLOGY



The following table is to list out the acronyms that have been applied throughout the document.

Term	Definitions
ATTO	Commercial performance benchmark application
DDR	Double data rate (SDRAM)
ASPM	Active States Power Management
APST	Autonomous Power State Transition
LBA	Logical block addressing
MTBF	Mean time between failures
PCIe	PCI Express / Peripheral Component Interconnect Express
S.M.A.R.T.	Self-monitoring, analysis and reporting technology

9. BARCODE DESCRIPTION

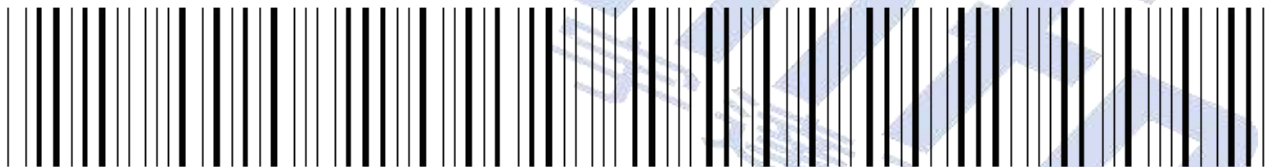

M 2 P 4 2 D E 2 5 6 G B A D P

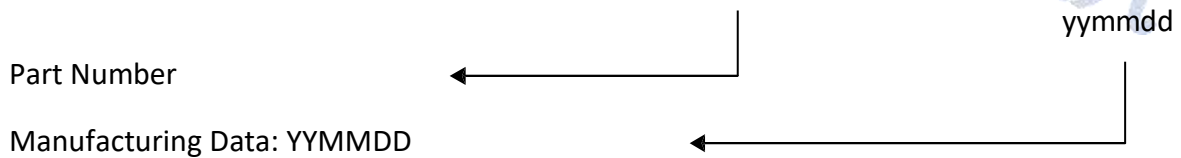

10. PARTNUMBER DECODER



M2P-42DEX⁸X⁹X¹⁰X¹¹X¹²X¹³X¹⁴X¹⁵X¹⁶X¹⁷

X ¹ X ² X ³	X ⁴ X ⁵	X ⁶ X ⁷	X ⁸ X ⁹ X ¹⁰ X ¹¹ X ¹²	X ¹³	X ¹⁴	X ¹⁵	X ¹⁶ X ¹⁷	
M2P	42	DE	60GB 120GB 240GB 480GB 960GB 1920G	64GB 128GB 256GB 512GB 001TB 002TB	A: 3D TLC Standard (0°C ~ +70°C) B: 3D TLC Industrial (-40°C ~ +85°C) J: 3D TLC Extend (-25°C ~ +85°C) V: 3D pSLC Standard (0°C ~ +70°C) W: 3D pSLC Industrial (-40°C ~ +85°C)	D	P	blank

